

MANISTOR 200 kg



Manual wall winch 200 kg.

Use:

- Lifting operation only
- Indoor or outdoor
- Wall-mounted position
- Sports room
- Shows, stage equipment
- Industry
- Lifting billboard

Comply with Machines Directive 2006/42/EC. Developed and manufactured in accordance with standard NF E N 13157.

Technical properties

- Light.
- Ergonomic, pleasant to use.
- Small.
- Easy to install (3 points of fixation) and to use.
- Aluminium structure.
- Mechanical parts with anti-corrosion treatment.
- Polymer drum.
- Automatic brake.
- Two ratchets for maximum safety.
- Very safe rope clamp with two pressure screws.
- Removable handle. Two-material handle (soft touch).
- Back-stop system.

Technical characteristics of MANISTOR 200 kg

Capacity 1st layer kg	300
Capacity top layer kg	200
Nb of layers	4
Wire rope cap. 1st layer m	1
Wire rope cap. top layer m	6.5
Wire rope Ø mm	4
Weight (without wire rope) kg	3
Lift per crank revolution mm	50
Max. hand force on crank kg	12

Dimensions

A mm	227
B mm	94
C mm	9
D mm	250
E mm	194
F mm	Ø 11
G mm	211
H mm	182
I mm	45
J mm	44
K mm	164

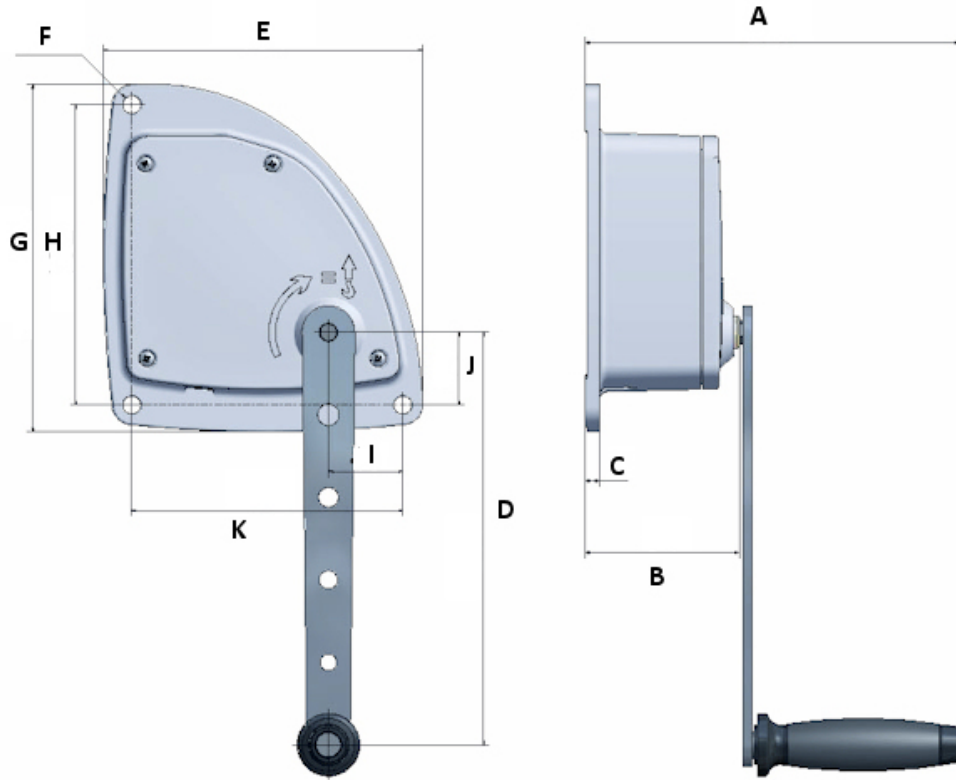

Technical characteristics of the other models of the range

References	MANISTOR100	MANISTOR200
Capacity 1st layer kg	150	300
Capacity top layer kg	100	200
Nb of layers	5	4
Wire rope cap. 1st layer m	1.5	1
Wire rope cap. top layer m	10	6.5
Wire rope Ø mm	3	4
Weight (without wire rope) kg	1.9	3
Lift per crank revolution mm	153	50
Max. hand force on crank kg	18	12



HUCHEZ's advice

Easy to install and to use, designed for outdoor and indoor work.



HUCHEZ
9, Grande Rue
60420 FERRIERES – France
☎ +33 (0) 3 44 51 11 33
Site internet : www.huchez.com
E-mail : contact@huchez.fr



**SERVICE
CLIENTS**

Pour en savoir plus, n'hésitez pas à nous contacter !
To know more, please contact us!