

TIREX 150 kg - standard model



Hand spurgear winch 150 kg, standard model (with zinc-plated steel mounting plate).

Use:

- Lifting or pulling/hauling operations
- Indoor - Outdoor
- Operating temperature between -10°C and +50°C
- Flat position
- Lifting doors
- Opening of traps
- On trailers, masts...

Comply with Machines Directive 2006/42/EC. Developed and manufactured in accordance with standard NF E N 13157.

Technical properties

- A new generation, compact winch taking advantage of the qualities of composite materials and aluminium, especially their anti-corrosion properties.
- High force/compact and density ratio.
- Many possibilities of wire rope exit (over 250°).
- Ergonomically and comfortably shaped crank grip.
- Removable crank.
- Stainless steel spring and pawls.
- Automatic brake.
- Zinc-plated steel mounting plate.
- Disengageable drum, no load only, associated with a failsafe system in the rope wind direction (patented).
- Planetary reducer in a sealed casing.
- Gear system with satellite pinions offering excellent mechanical balance and reducing the effort required on the crank.

Technical characteristics of TIREX 150 kg - standard model

Capacity 1st layer kg	250
Capacity top layer kg	150
Nb of layers	6
Wire rope cap. 1st layer m	2,5
Wire rope cap. top layer m	24
Wire rope Ø mm	4
Weight (without wire rope) kg	3,7
Lift per crank revolution mm	40
Max. hand force on crank kg	8

Dimensions

A mm	61
B mm	100
C mm	320
D mm	189
E mm	144
F mm	250
G mm	126
H mm	60
I mm	11

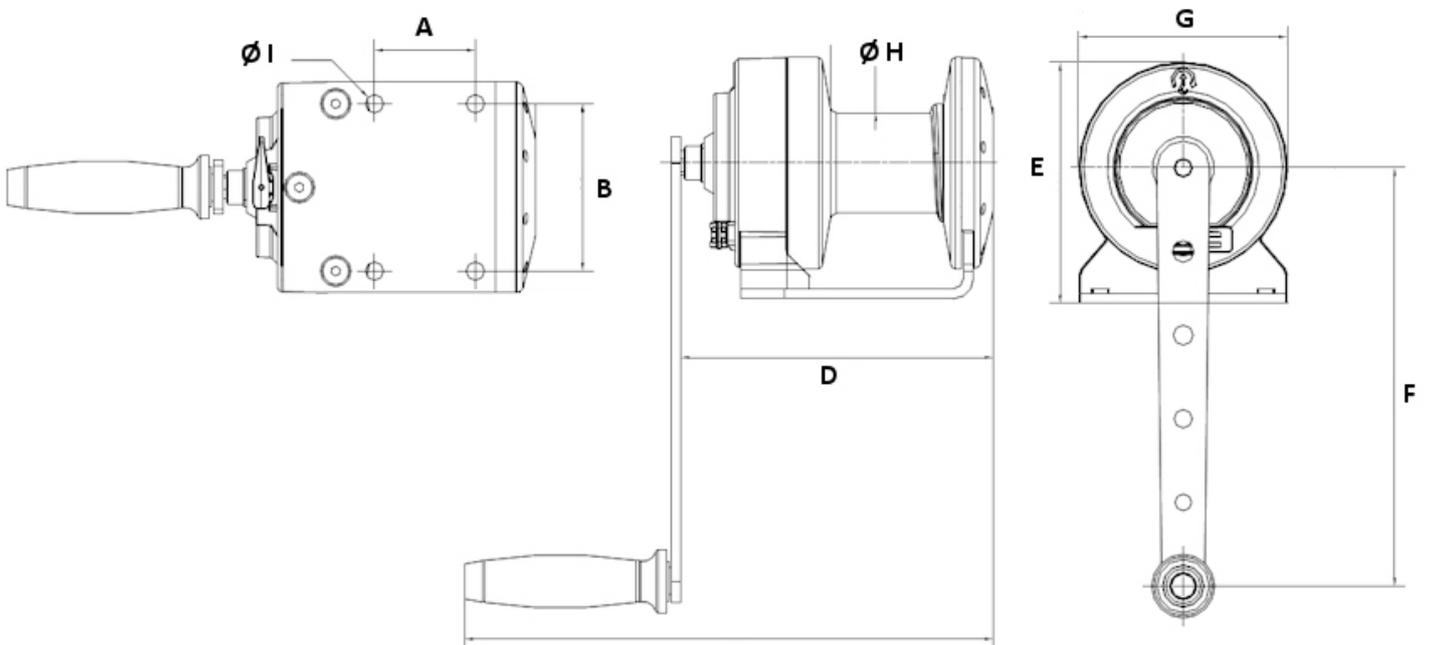

Technical characteristics of the other models of the range

References	TIREX300INOX	TIREX300	TIREX150	TIREX150INOX
Capacity 1st layer kg	400	400	250	250
Capacity top layer kg	300	300	150	150
Nb of layers	3	3	6	6
Wire rope cap. 1st layer m	2	2	2,5	2,5
Wire rope cap. top layer m	8,5	8,5	24	24
Wire rope Ø mm	5	5	4	4
Weight (without wire rope) kg	3,7	3,7	3,7	3,7
Lift per crank revolution mm	41	41	40	40
Max. hand force on crank kg	14	14	8	8



HUCHEZ's advice

High force/compact and density ratio, many possibilities of wire rope exit (over 250°), clutch release impossible when loaded, accessible and very safe self-tightening rope attachment, rope guide for correct winding and a maximum safety with two ratchets.



HUCHEZ
9, Grande Rue
60420 FERRIERES – France
☎ +33 (0) 3 44 51 11 33
Site internet : www.huchez.com
E-mail : contact@huchez.fr



**SERVICE
CLIENTS**

Pour en savoir plus, n'hésitez pas à nous contacter !
To know more, please contact us!

