

HTWP - TORQUE WRENCH PUMPS



Working pressure 700 Bar

Choice of air or electric power options

Supplied complete with hand pendant controller

Hi-Force hydraulic torque wrench pumps are compatible for use with all Hi-Force hydraulic torque wrenches. All models are 700 Bar maximum working pressure, fitted with an easily accessible and adjustable torque setting pressure relief valve, and are available as air driven or electric driven pump units. All pumps are supplied with a remote operation, push button hand pendant controller with three metres of control line cable. Glycerine filled, easy to read, dual scale (0-700 Bar/0-10,000 PSI) hydraulic pressure gauges are fitted as standard to all models. Air driven versions also include an integral inline filter, regulator, lubricator system with airline pressure gauge and an exhaust air cooling system.

- >> Dual scale glycerine filled pressure gauge
- >> Two speed operation
- >> Externally adjustable torque setting valve
- >> Protective rollbar carrying frame
- >> Air pressure gauge and filter-regulator-lubricator unit (air powered pumps only)
- >> Integral oil cooling system (air powered pumps only)
- >> Reservoir oil sight level gauge
- >> Auto retract function (electric powered pumps only)
- >> Choice of standard hose length available, see page 90

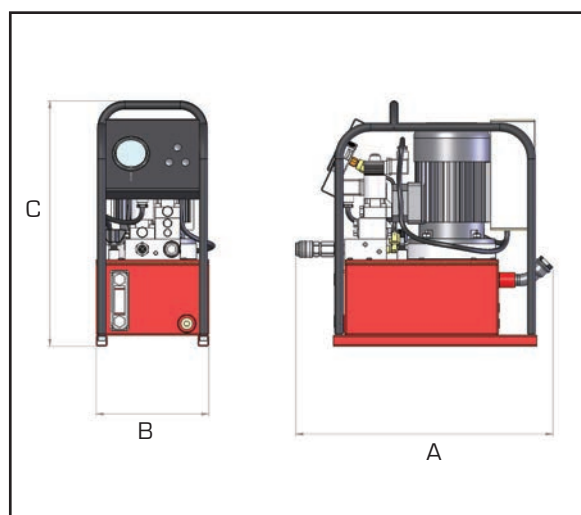

Model number	Max pressure Bar	Power supply	Motor rating kW	Displacement l/min		Changeover pressure Bar	Weight kg	Dimensions in mm		
				low pressure	high pressure			A	B	C
HTWP2140P	700	7 Bar	1.50	6.1	0.51	60	28.0	468	205	445
HTWP2141AR	700	110 volt	0.75	3.9	0.36	60	34.0	468	205	445
HTWP2141ARH	700	110 volt	0.75	3.9	0.36	60	34.0	468	205	445
HTWP2142AR	700	240 volt	0.75	3.9	0.36	60	34.0	468	205	445
HTWP2142ARH	700	240 volt	0.75	3.9	0.36	60	34.0	468	205	445

Note: Pumps with suffix 'H' in the model number are supplied with 60Hz electric motor.

F